

products.³⁴ The independent synthesis of **60** rigorously established the stereochemistry of the methoxyl function in **60**. Thus it was established that the nucleophile added *trans* to the attacking nitrenium ion. The stereochemistry of the methoxyl functions of **54** and **61** was assigned on this basis.

Summary

Nitrenium ions have been rigorously established as useful intermediates in a variety of synthetic applications. The chemistry of nitrenium ion singlets has been explored in relation to molecular rearrangements and new routes for forming carbon–nitrogen bonds. It has been chemically demonstrated that nitrenium ion singlets may be converted to nitrenium ion triplets. Since it is evident that nitrenium ions (both singlet and triplet forms) are potentially very important species for the synthesis of a wide variety of nitrogen-containing compounds, we are continuing our efforts to develop new and useful applications of nitrenium ion chemistry.

I wish to thank the National Cancer Institute, Public Health Service, for Grant CA-07110 which supported this work, and the Alfred P. Sloan Foundation for a fellowship. I also wish to acknowledge the impressive efforts of my collaborators mentioned in the references, who have contributed much to the knowledge of nitrenium ions.

Determination of the Chemical Structure of Organic Compounds at the Microgram Level by Gas Chromatography

MORTON BEROZA^{1,2}

Entomology Research Division, Agricultural Research Service, U. S. Department of Agriculture, Beltsville, Maryland 20705

Received July 14, 1969

Chemists, especially those dealing with natural products, are frequently confronted with the problem of identifying substances they have isolated in insufficient amount. Frustrations of this kind are probably more common today than in the past because of the remarkable success and ease with which the chemist can separate microgram and lesser amounts of a pure compound from complex mixtures by means of gas and other forms of chromatography.

At the U. S. Department of Agriculture we are plagued with this problem of identification in our efforts to elucidate the chemical structure of insect sex attractants, which we need to combat insect pests. Attractants of this kind are used to bait traps that are deployed around our ports of entry to detect incipient infestations of imported insect pests. Should one of the target insects be found, the infestation can be eradicated before it can spread. One such operation saved the U. S. Department of Agriculture more than nine million dollars in potential eradication costs.

One of the biggest handicaps in our efforts to determine the structure of insect sex attractants is the enormous number of insects needed to obtain a minute amount of pure attractant; the chemical does have to

be pure before its structure can be determined. Since these insect collections are costly, structure determinations must be carried out on a limited amount of material. This is not a specialized need because, regardless of a chemist's interest, being able to make identifications with less material is bound to accelerate progress in virtually all fields, but especially in the life sciences. Spectral probes, such as ir, uv, nmr, and mass spectrometry, are invaluable and are a first resort, but more and better techniques are needed to cope with problems of this kind.

Several of the techniques to be described were devised to fill this need. Most of these combine a chemical reaction with gas chromatography and can be used with 1 to a few micrograms of substance for identification or for some other analytical advantage.

As anyone who has had to deal with minute amounts of substance soon learns, the value of manipulative skills and techniques is most important, and apparatus that allows those less than generously endowed with such skills to perform difficult analyses is certainly needed. The emphasis on means of getting a job done is therefore an important part of the quest to do more with less.

Carbon-Skeleton Chromatography

Carbon-skeleton chromatography^{3a} strips off all func-

(1) Recipient of the 1969 American Chemical Society Award in Chromatography and Electrophoresis, sponsored by Lab-Line Instruments, Inc.

(2) Presented in part at the 157th National Meeting of the American Chemical Society, Minneapolis, Minn., on April 15, 1969; award address.

(3) (a) M. Beroza, *Anal. Chem.*, **34**, 1801 (1962); (b) M. Beroza and F. Acree, Jr., *J. Ass. Offic. Agr. Chem.*, **47**, 1 (1964).

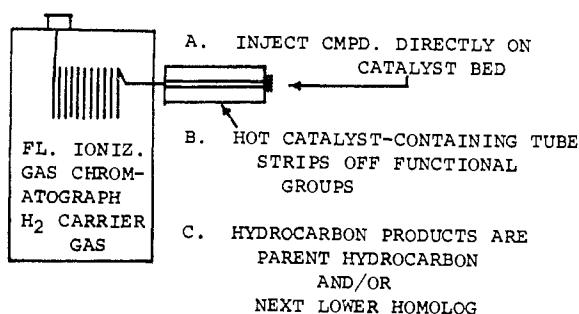

Figure 1. Carbon-skeleton chromatography.

tional groups from a compound and saturates double and triple bonds. The carbon skeleton thus produced is used to help determine structure.^{3b}

Figure 1 is a schematic representation of the apparatus. A hot catalyst-containing tube is introduced into the gas chromatographic pathway just ahead of the injection port of the usual flame ionization gas chromatograph, and hydrogen is used as the carrier gas. The catalyst is usually 1% palladium on a gas chromatographic support; it is held at 300°. As the injected compound passes the hot catalyst, the compound is chemically degraded to its carbon skeleton or to its next lower homolog (more on this later). The hydrocarbon products pass into the gas chromatograph and are identified by their retention times (t_R). (If more sophisticated instrumentation is available, *e.g.*, a mass spectrometer, the identification can be made more certain.)

The carbon skeleton is often a good starting point for a structure determination. With the t_R of the carbon skeleton, the chemist can add the t_R increments for the various functional groups, and with other information at hand can frequently come close to identifying a compound or its functional groups from the t_R of the original compound.

One carbon-skeleton apparatus^{4a} holds a 9-in. length of the catalyst in an aluminum tube having a $3/16$ -in. bore, actually about 2 g of catalyst. The so-called neutral catalyst^{5a} is prepared by evaporating to dryness a solution of PdCl_2 in 5% acetic acid in contact with the support and sufficient alkali to neutralize the HCl that forms when the PdCl_2 is reduced ($\text{PdCl}_2 + \text{H}_2 \rightarrow \text{Pd} + 2\text{HCl}$). The catalyst is activated by gradually heating it to the analysis temperature in a slow stream of hydrogen.

In carbon-skeleton chromatography hydrogenation, dehydrogenation and hydrogenolysis may occur. Hydrogenation, which is the saturation of multiple bonds, greatly reduces the number of possibilities in determining the carbon skeleton. Dehydrogenation, which is the abstraction of hydrogen, takes place with cyclohexane-containing compounds and gives aromatic structures. Elevated catalyst temperatures, such as

330°, favor such aromatizations; lower temperatures, between 200 and 250°, favor hydrogenation over dehydrogenation.^{5b} (Dehydrogenations may be used in a manner similar to the classical zinc or selenium dehydrogenations to determine the identity of ring structures.^{3b}) Finally, hydrogenolysis involves the cleavage of functional groups from a molecule and the addition of a hydrogen atom to each of the cleaved ends.

In the typical reactions that follow (catalyst temperature 300°, H_2 flow rate 20 cc/min), the parent hydrocarbon is obtained from halides, sulfides and compounds with secondary oxygen or nitrogen functions.

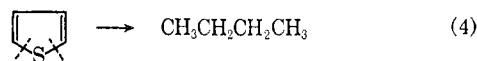
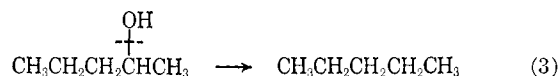
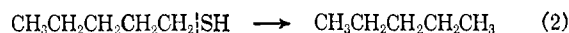

Reaction 4 shows that more than one reaction can occur simultaneously, *i.e.*, hydrogenolysis of the C-S bonds and hydrogenation of the double bonds.

When an oxygen or nitrogen function is on the end carbon atom (aldehyde, primary alcohol, ester, ether, amine, amide, carboxylic acid), the next lower homolog of the parent hydrocarbon is obtained, although the parent compound may be produced concurrently.

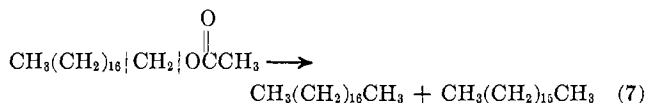
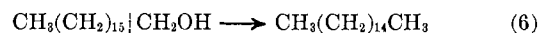
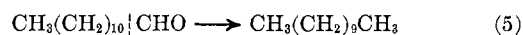

The aldehyde and alcohol usually give only the next lower homolog, and the ester gives more of the parent hydrocarbon than the next lower homolog. These products and their ratios frequently shed light on the identity of the functional groups in a molecule.

In the degradative process a chloro compound produces HCl , a sulfide H_2S , and a nitrogen compound NH_3 ; other nonhydrocarbon products may be H_2O , CO , CO_2 , HBr , HI . None of these products registers on the flame-ionization detector, and they may therefore be ignored for purposes of this analysis.

In essence, then, a compound subjected to carbon-skeleton chromatography gives the parent hydrocarbon (with multiple bonds saturated) except when an oxygen or nitrogen function is on the end carbon atom, in which case the end carbon atom is removed partly or entirely with the oxygen or nitrogen function to give the next lower homolog of the parent hydrocarbon.

Carbon-skeleton chromatography is not advanced as a quantitative procedure. Thus, products from compounds with several polar groups or those with 20 or more carbon atoms in their molecules come through in low yield, and sometimes not at all. However, the proper products from the polar and high-molecular-

(4) (a) Available from National Instruments Laboratory, Rockville, Md.^{4b} (b) Mention of proprietary products is for identification only.

(5) (a) M. Beroza and R. Sarmiento, *Anal. Chem.*, **35**, 1353 (1963); (b) M. Beroza and R. Sarmiento, *ibid.*, **36**, 1744 (1964).

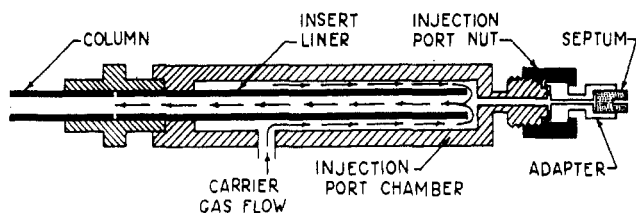
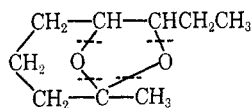

Figure 2. Cross-sectional view of insert liner that holds the catalyst in the injection port and adapter for keeping the septum cooler than the injection port.

weight compounds are readily obtained by using shorter catalyst lengths. A 4-in. length of catalyst was found suitable for compounds, in the C_{12} to C_{30} range.⁶ When a short length of catalyst, e.g., a 3-in. length, is sufficient, it is often possible to pack the catalyst in the injection port, and no special apparatus is required. This arrangement⁷ is shown in Figure 2. A stainless-steel adaptor was used to hold the septum a small distance from the hot zone to reduce the septum temperature and cut down on septum bleed. As with all gas chromatography, the system must be tested to be certain there is no leakage. The testing of model compounds before proceeding with unknowns is also standard procedure in this and the following procedures. Several instances in which the technique has proved useful follow.

Carbon-skeleton chromatography was used by Silverstein and coworkers⁸ to elucidate the structure of brevicomin, an ingredient of the sex attractant of the western pine beetle. A large number of possible struc-



tures based on spectral evidence was narrowed down to a few based on the production of nonane in carbon-skeleton chromatography. The four cleavages (dotted lines), which resulted from the hydrogenolysis of secondary oxygen bonds, show how nonane was obtained. The structure was verified by synthesis. In this work an integrated system for collecting a sample from a gas chromatograph and reintroducing it through a carbon-skeleton apparatus was used by Brownlee and Silverstein.⁹ This very useful technique exemplifies a procedure employed to overcome difficulties in collecting and transferring minute amounts of compound.

Recently Adhikary and Harkness¹⁰ reported that a catalyst consisting of Pt on siliconized glass beads allowed them to determine the carbon skeleton of steroids. (Our Pd catalyst did not perform properly.) This work opens a new and important area of usefulness for carbon-skeleton chromatography.

(6) M. Beroza and R. Sarmiento, *Anal. Chem.*, **37**, 1040 (1965).

(7) B. A. Bierl, M. Beroza, and W. T. Ashton, *Mikrochim. Acta*, 637 (1969).

(8) R. M. Silverstein, R. G. Brownlee, T. E. Bellas, D. L. Wood, and L. E. Browne, *Science*, **159**, 889 (1968).

(9) R. G. Brownlee and R. M. Silverstein, *Anal. Chem.*, **40**, 2077 (1968).

(10) P. M. Adhikary and R. A. Harkness, *ibid.*, **41**, 470 (1969).

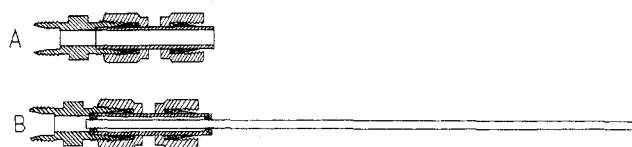

Figure 3. Oven hydrogenator A and injection-port hydrogenator B.

Instantaneous Hydrogenation

Hydrogenation is widely used to determine the structure of unsaturated compounds and to determine the olefin content of a wide variety of mixtures. The simplest means of hydrogenating microgram amounts of sample is "instantaneously" in the chromatographic pathway by using a hydrogenation catalyst and a hydrogen carrier gas. This procedure was first used successfully for hydrocarbons. In 1965 Mounts and Dutton¹¹ expanded this technique to the hydrogenation of methyl esters of unsaturated fatty acids. They devised a clever apparatus that held a 1.5-in. precolumn of catalyst at 200° on the injection port of the instrument. Owing to the mild conditions used, their apparatus hydrogenated double bonds quantitatively without the hydrogenolysis obtained by carbon-skeleton chromatography. This technique was investigated further because it held considerable promise not only for the analysis of fatty acid methyl esters but for instantaneously hydrogenating a wide variety of compounds at the microgram level.

Since the gas chromatography of the fatty acid methyl esters of oils is conducted at 200°, there was no reason why the catalyst could not be placed in the gas chromatographic oven. The small hydrogenator shown in Figure 3A, inserted between the exit of the injection port and the chromatographic column, produced the desired results.¹² The hydrogenator is a simple stainless steel Swagelok union attached to a short length of stainless steel tubing to hold the catalyst. It can be assembled in a few minutes.

Mounts and Dutton used mostly a 1.5-in. length of nickel on kieselguhr catalyst, but they also tested the palladium catalyst that we used in carbon-skeleton chromatography. In trials with our catalyst, we were surprised to find that a 0.25-in. length of catalyst (held between glass wool plugs) was adequate to achieve quantitative hydrogenation of the methyl esters of unsaturated acids. Since so little catalyst was needed to hydrogenate compounds completely, the catalyst could be placed in the injection port. The hydrogenator shown in Figure 3B accomplished this purpose.¹² It is the same as the oven hydrogenator in Figure 3A except that it has silver-soldered within it a long tube that holds the catalyst in the injection port. This hydrogenator is more versatile than the oven hydrogenator because the catalyst can be held at one temperature and the oven at another temperature.

Results obtained with a mixture of fatty acid methyl

(11) T. L. Mounts and H. J. Dutton, *ibid.*, **37**, 641 (1965).

(12) M. Beroza and R. Sarmiento, *ibid.*, **38**, 1042 (1966).

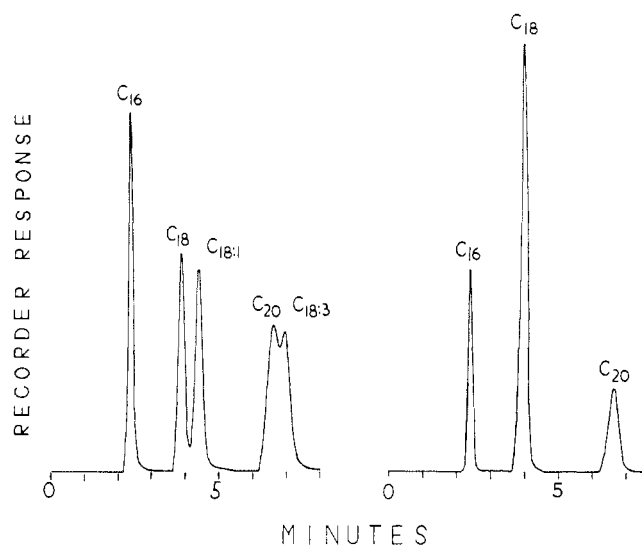

Figure 4. Chromatograms of a mixture of methyl palmitate (C_{16}), stearate (C_{18}), oleate ($C_{18:1}$), linolenate ($C_{18:3}$), and arachidate (C_{20}) made without hydrogenator (left) and with the injection-port hydrogenator (right).

esters are shown in Figure 4 both with and without the hydrogenator in the gas chromatographic pathway. The hydrogenation is quantitative.

More important than the simplified equipment for conducting hydrogenations is the fact that a wide variety of unsaturated compounds—alcohols, amides, amines, ketones, esters, ethers, nitriles, and others—may be hydrogenated by this procedure.¹² However, with certain types of compounds (halides, aldehydes, and mercaptans), hydrogenolysis does occur to some extent. The partial hydrogenolysis will upset quantitative estimations, but it does not interfere with structure determinations because the hydrocarbon fragments that form on hydrogenolysis emerge far ahead of the hydrogenated product that we wish to see.

If a short length of stainless steel needle stock tubing (22 gauge) is inserted through the catalyst, both the original compound and the hydrogenated product appear on the chromatogram. The compound passing through the needle stock tubing is obviously unaffected, while the major portion of the compound penetrates the catalyst and is hydrogenated. In this manner, the separation factor (ratio of t_R of unsaturate to t_R of saturated analog) is easily determined with a single injection of the compound. Separation factors are characteristic of a compound and are useful for establishing the number of double bonds and often the position of double bonds for confirmation of identities.

Catalyst temperature does not appear to be critical. Usually it has to be at least 150° to assure complete hydrogenation, and temperatures up to 250° have given good results.

Issenberg, *et al.*,¹³ have used the hydrogenator with 10–15 mg of 1% neutral palladium catalyst on Chromosorb W to elucidate the structure of flavor components. They place the hydrogenator at the end of a gas chromatographic column that leads to a fast-scan mass

(13) P. Issenberg, A. Kobayashi, and T. J. Myaliwy, submitted for publication.

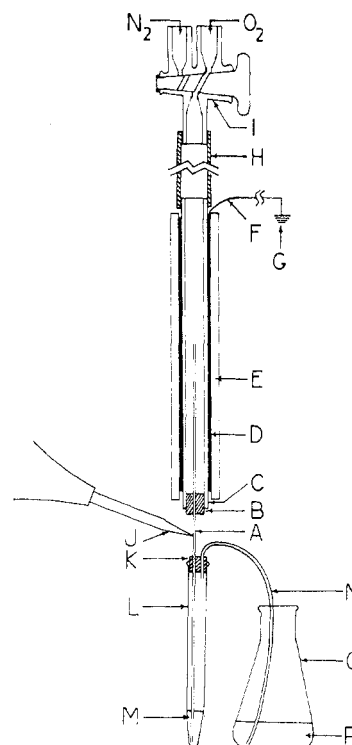

Figure 5. Apparatus for ozonolysis of compounds. See ref 16 and 18 for details.

spectrometer and include a switching valve to allow the gas chromatographic effluent either to by-pass the catalyst or to pass through the catalyst. In their work with a series of hexenols, Issenberg, *et al.*, had to cope with *cis* and *trans* double bonds as well as with positional isomers. A comparison of the parent masses of the hydrogenated and unhydrogenated compounds from a peak disclosed the number of double bonds. It was also possible to identify the fully saturated alcohol, which facilitated the identification of the unsaturated analogs. With their elegant setup, they were able to derive such information on submicrogram quantities of flavor chemicals.

Locating Double-Bond Position

If one finds double bonds in a compound, the next logical step is to determine their position. Ozonolysis has proved effective for this purpose. The value of ozonolysis for locating double bonds in methyl esters of unsaturated fatty acids had been demonstrated by Davison and Dutton¹⁴ and Nickell and Privett.¹⁵

At the outset, it was found that a small ozonizer for the analysis of microgram amounts was not available. An ozonizer generally consists of a grounded and ungrounded electrode through which oxygen flows, and ozone is generated from the oxygen when a source of high voltage (*e.g.*, a vacuum tester) is applied to the ungrounded electrode. Accordingly, the easily assembled ozonizer¹⁶ shown in Figure 5 was set up.

(14) V. L. Davison and H. J. Dutton, *Anal. Chem.*, **38**, 1302 (1966).

(15) E. C. Nickell and O. S. Privett, *Lipids*, **1**, 166 (1966).

(16) M. Beroza and B. A. Bierl, *Anal. Chem.*, **38**, 1976 (1966). A modified version of this apparatus and all reagents for ozonolysis are available from Supelco Corp., Bellefonte, Pa.

(Another ozonizer¹⁷ has some improvements over that shown.)

In a typical analysis¹⁸ 25 μg of compound in 100 μl of solvent is held in reaction tube L at -70° as oxygen at 10 cc/min passes into the solution, and the vacuum tester is applied to the inner electrode. The reaction is virtually instantaneous, and in about 15 sec the indicating solution P (starch-KI- H_2SO_4) turns blue, indicating the presence of excess ozone. The three-way stopcock is reversed to sweep out the oxygen with nitrogen. The reaction tube is slipped off the ozonizer, and about 0.5 mg of powdered triphenylphosphine is dropped into the tube, which is stoppered and swirled. When the solution reaches room temperature (10 min), a 20- μl aliquot (ca. 5 μg) is injected into the gas chromatograph. Double-bond position is determined from the fragments produced.

The ozonide that forms is cleaved by the triphenylphosphine to aldehydes or ketones¹⁹ depending on whether the olefin is substituted or not. Equations 8 and 9 show the over-all reactions.

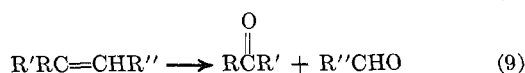

Carbon disulfide appeared to be the best solvent for ozonolysis in our analyses, mainly because it obscures much less of the chromatogram than other solvents normally used. With CS_2 , peaks with retention times equal to or greater than that of valeraldehyde are visible. For the part of the chromatogram obscured by CS_2 , another run in pentyl acetate was made. In these chromatograms, aldehydes or ketones with retention times less than that of valeraldehyde appear before the pentyl acetate starts to emerge.

Table I shows some of the large variety of compounds

Table I
Gas Chromatographic Analysis of Ozonolysis Products from Various Compounds

Compound	Products identified ^a
$\text{CH}_3\text{CH}_2\text{CH}=\text{CH}(\text{CH}_2)_2\text{OH}$	$\text{CH}_3\text{CH}_2\text{CHO}$, +
$\text{CH}_3(\text{CH}_2)_7\text{CH}=\text{CH}(\text{CH}_2)_7\text{CH}_2\text{NH}_2$	$\text{CH}_3(\text{CH}_2)_7\text{CHO}$, +
$\text{CH}_3\text{CH}_2(\text{CH}=\text{CHCH}_2)_6\text{CH}_2\text{COOCH}_3$	$\text{CH}_3\text{CH}_2\text{CHO}$, +
	$\text{CH}_3\text{C}(=\text{O})\text{CH}_3$, +
	$\text{CH}_3(\text{CH}_2)_4\text{CHO}$
$\text{C}_6\text{H}_5\text{C}(\text{CH}_3)=\text{CH}_2$	$\text{C}_6\text{H}_5\text{COCH}_3$
$p\text{-CH}_3\text{OC}_6\text{H}_4\text{CH}=\text{CHCH}_3$	CH_3CHO , $p\text{-CH}_3\text{OC}_6\text{H}_4\text{CHO}$
$\text{C}_6\text{H}_5\text{CH}=\text{CHP}(=\text{O})(\text{OCH}_2\text{CH}_3)_2$	$\text{C}_6\text{H}_5\text{CHO}$, +
$\text{C}_6\text{H}_5\text{CH}=\text{CHCONHCH}_2\text{CH}_2\text{CH}_3$	$\text{C}_6\text{H}_5\text{CHO}$

^a Products identified by retention time. + signifies that another major product was detected, but that a known compound was not available to check its identity.

(17) M. Beroza and B. A. Bierl, *Mikrochim. Acta*, 720 (1969).

(18) M. Beroza and B. A. Bierl, *Anal. Chem.*, 39, 1131 (1967).

(19) R. A. Stein and N. Nicolaidis, *J. Lipid Res.*, 3, 476 (1962).

(halides, aromatics, ethers, heterocyclics, and phosphates) that produced the expected products. The generation of acetone from the isopropylidene group in the fourth compound listed may be of interest to the natural products chemist because ozonolysis provides a simple means of recognizing this group, which is present in many compounds of natural origin.

Although several reports in the literature (e.g., Greiner²⁰) show that conjugated double bonds are ozonized more slowly than unconjugated ones, the appropriate products were obtained from compounds containing conjugated double bonds. However, a few unsaturated structures (triple bonds and α,β -unsaturated nitriles) did resist ozonolysis. This finding may be useful for detecting and possibly for analyzing or establishing the position of such groups in a molecule.

The structure of the following terpene alcohol, one of the ingredients of the boll weevil sex attractant,²¹ was provided in part by microozonolysis when it was shown to yield 3,3-dimethylcyclohexanone.

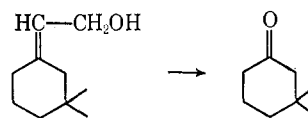

Reaction Loops

Compounds containing a certain functional group or structure may be "subtracted" (or detained) by a chemical in the gas chromatographic pathway. These effects are recognized by comparing chromatograms made with and without exposure to the chemical. Thus, primary and secondary alcohols are removed by boric acid,^{22,23} aldehydes by the FFAP liquid phase,²⁴ aldehydes and ketones by hydroxylamine,²⁵ and carboxylic acids by zinc oxide.¹⁴

Subtractions are usually accomplished by including within the system a short length of packing consisting of the reactive chemical coated on an inert gas chromatographic support. A "reaction loop" of this kind may be made from a 6-in. coil of 0.25-in. o.d. stainless steel tubing that is fitted with Swagelok fittings for easy insertion into the gas chromatographic system either before or after the analytical column.⁷ Length (e.g., more coils) or temperature of the loop may be varied as needed. Compounds retained may often be released into the gas chromatograph by raising the temperature of the loop; compounds may also be passed through a reaction loop and the products immobilized in a cold trap for subsequent return to the gas chromatograph by means of a series of four-way valves.²⁶ Compounds

(20) A. Greiner, *J. Prakt. Chem.*, 13, 157 (1961).

(21) J. H. Tumlinson, R. C. Gueldner, D. D. Hardee, A. C. Thompson, P. A. Hedin, and J. P. Minyard, 157th National Meeting of the American Chemical Society, Minneapolis, Minn., April 1969, Abstract AGFD-40.

(22) R. M. Ikeda, D. E. Simmons, and J. D. Grossman, *Anal. Chem.*, 36, 2188 (1964).

(23) F. W. Hefendehl, *Naturwissenschaften*, 51, 138 (1964).

(24) R. R. Allen, *Anal. Chem.*, 38, 1287 (1966).

(25) Y. G. Osokin, V. S. Feldblum, and S. I. Kryukov, *Neftekhimiya*, 6, 333 (1966).

(26) R. Rowan, Jr., *Anal. Chem.*, 33, 658 (1961).

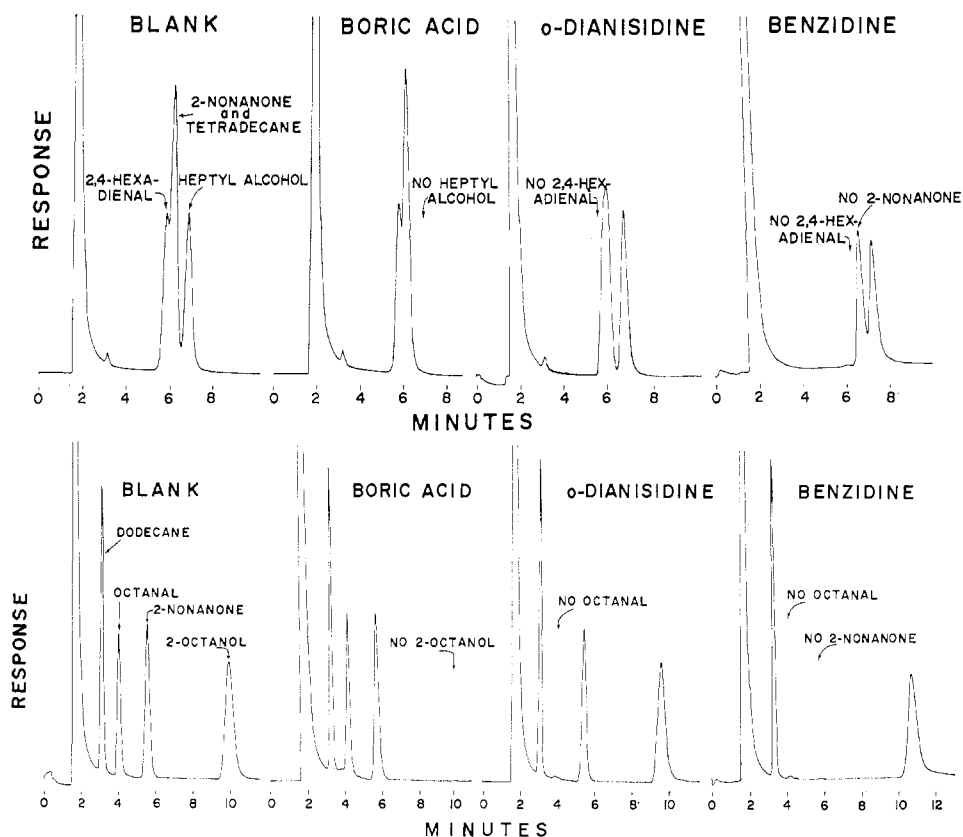

Figure 6. Chromatograms of a mixture of compounds passed through a blank loop (no chemical) and loops of boric acid, *o*-dianisidine, and benzidine.

are thus removed, delayed, or changed to others with different retention times to aid identification or to eliminate their interference in the analysis or collection of other compounds. In this regard, a recent study on the subtraction of alcohols, aldehydes, ketones, epoxides, and acids is pertinent.⁷

The use of subtractive loops for functional group analysis is thus far of limited reliability because not enough data are available on the action of the loops with compounds other than those they are intended to subtract or with compounds having groups or structures near the functional group of interest. For example, in a study on the subtraction of alcohols with a boric acid loop placed after the analytical column, certain unsaturated primary and secondary alcohols, unlike their saturated analogs, were not subtracted. It was found that the alcohols were allylic, and the compounds were being dehydrated to conjugated dienes. With the hydroxyl group removed, the compound was not subtracted.

Despite their limitations, the loops can be most useful. Consider the chromatogram obtained from an ozonolysis determination described earlier. There is no indication as to whether the peaks arise from aldehydes or ketones. However, the inclusion of a loop⁷ containing 5% *o*-dianisidine on a gas chromatographic support provides this information by subtracting aldehydes and allowing ketones to pass (provided they do not also contain an aldehyde group). Thus, the double bonds

in compounds that are alkyl substituted can be identified (see eq 8 and 9).

The zinc oxide loop for subtracting carboxylic acids gave some unexpected results when a variety of acids were checked with a loop containing 10% ZnO powder.⁷ Carboxylic acids were retained except for those that were α substituted. Peaks of the latter were reduced in height three- to tenfold and markedly delayed in retention time. This behavior suggests the use of the ZnO loop to determine the presence of α substitution in unknown carboxylic acids.

Figure 6 illustrates the subtractive technique. Chromatograms are shown of the original mixture (blank), the subtraction of alcohols with a boric acid loop, the subtraction of aldehydes with an *o*-dianisidine loop, and the subtraction of aldehydes and ketones with a benzidine loop. As shown in the upper part of the figure, components of a mixture giving overlapping peaks may be removed with the reaction loops. The subtraction of one or more substances may therefore allow the collection or analysis of another substance.

The subtraction of compounds need not be complete to provide structural information. The use of silver nitrate to retard the passage (increase retention time) of olefins (compared to saturated compounds) is well known and widely used to separate compounds chromatographically. In another instance, *cis-trans* conjugated dienes were distinguished by passing them through a chloromaleic anhydride column; the *trans*

isomer reacts more readily than its *cis* counterpart and more of it is removed.²⁷

Detectors

In the classical approach to the determination of chemical structure, the analysis of an unknown compound for its elements was a first requisite, and the analyst usually had to be quite skilled to get reliable results with a 0.1-mg sample. The availability within the past decade of a variety of gas chromatographic detectors has greatly facilitated the detection (and frequently estimation) of many elements in a molecule and has made elemental analysis possible at microgram and often nanogram levels. Furthermore, some detectors provide information on the presence of certain functional groups in a molecule.

The flame-ionization detector responds to CH₃, CH₂, and CH groups in a molecule at submicrogram levels and may therefore be used to detect carbon in a molecule. (It does not respond to CO or CO₂ and probably not to carbonyl groups in a molecule.) The electron-capture detector responds to a variety of compounds in the nanogram and even picogram range, *e.g.*, alkyl halides, sulfides, conjugated carbonyls, metal organics, nitro compounds, and nitriles. Its response to many types of compounds, which may be viewed as a lack of specificity, diminishes its diagnostic value; however, the detector can be used to check remarkably small amounts of compound for the presence of these groups or elements that are known to respond. A much greater specificity for detecting halogen or sulfur in a molecule can be obtained with the microcoulometric²⁸ or electrolytic conductivity²⁹ detector at the low nanogram level. For these detectors, the column effluent is usually subjected to combustion in oxygen, and the resulting hydrogen halide or SO₂ is determined in the microcoulometric or electrolytic conductivity cell.

The determination of organophosphates has become important since the use of the organophosphorus insecticides has become widespread. The thermionic detector, which is a flame-ionization detector having an alkali metal salt in or near its flame, responds to phosphorus compounds in the subnanogram range.³⁰ By modifying placement of the salt and electrode, the phosphorus response is repressed, and the response of organonitrogen compounds is enhanced.^{31,32}

The flame-photometric detector of Brody and Chaney^{33,34} has been used quite extensively for the analysis of pesticides containing phosphorus and/or

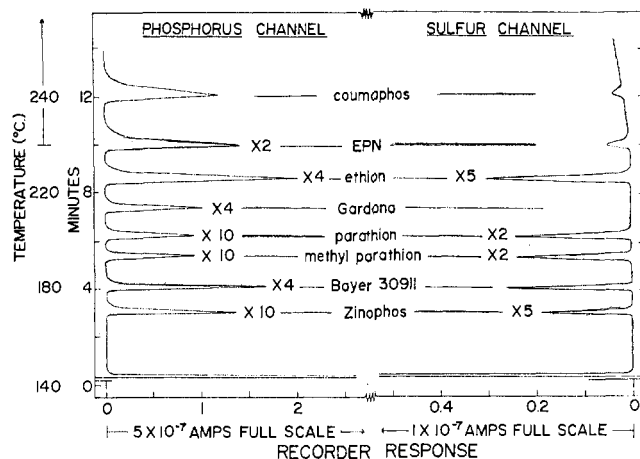

Figure 7. Dual-channel recording of 50-ng amounts of eight pesticides containing phosphorus and sulfur in a temperature-programmed run. See ref 36 for identification of pesticides and other details.

sulfur.³⁵ The column effluent is burned in a hydrogen-rich flame as it emerges from the column, and the light emission is monitored at 526 m μ to determine phosphorus compounds and at 394 m μ to determine sulfur compounds. In a dual version of this detector,³⁴ the phosphorus and sulfur detectors monitor the same burning effluent from opposite sides, and it is possible to determine the P/S ratio in a compound from the relative response to the two detectors.³⁶ A chromatogram from a temperature-programmed run of eight pesticides is shown in Figure 7. The flame-photometric detector is sensitive to subnanogram amounts of phosphorus and nanogram amounts of sulfur compounds.

The use of flame detectors appears to be an effective approach to the detection of elements in a molecule. In the combustion process, compounds are degraded to very small molecules (*e.g.*, HCl, SO₂, NH₃) or fragments which provide rather specific responses for elements under fixed conditions. Thus, a halogen detector³⁷ based on the familiar Beilstein effect is simply a flame-photometric detector that monitors the green light emission as halogen compounds pass through a copper mesh screen and enter the flame. A unique feature of the detector is that chlorine-, bromine-, and iodine-containing compounds can be distinguished by their response ratios at two hydrogen flow rates. This result signifies that the chemical species in the flame change as the composition of the gas entering the detector is varied. The investigation of such changes can lead to new and useful detectors for elements or elemental combinations.

Virtually all analytical instruments have been coupled with a gas chromatograph. Emerging compounds have been monitored in the infrared³⁸ and ultraviolet³⁹ re-

(27) E. Gil-Av and Y. Herzberg-Minzly, *J. Chromatogr.*, **13**, 1 (1964).

(28) D. M. Coulson, L. A. Cavanagh, J. E. DeVries, and B. Walther, *J. Agr. Food Chem.*, **8**, 399 (1960).

(29) D. M. Coulson, *J. Gas Chromatogr.*, **3**, 134 (1965).

(30) L. Giuffrida, N. F. Ives, and D. C. Bostwick, *J. Ass. Offic. Anal. Chem.*, **49**, 8 (1966). See also C. H. Hartmann, *Bull. Environ. Contam. Toxicol.*, **1**, 159 (1966).

(31) W. A. Aue, C. W. Gehrke, R. C. Trindle, D. L. Stalling, and C. D. Ruyle, *J. Gas Chromatogr.*, **5**, 381 (1967).

(32) C. H. Hartmann, *J. Chromatogr. Sci.*, **7**, 163 (1969).

(33) S. S. Brody and J. E. Chaney, *J. Gas Chromatogr.*, **4**, 42 (1966).

(34) Available from Tracor, Inc., Austin, Texas.

(35) M. Beroza and M. C. Bowman, *Environ. Sci. Technol.*, **2**, 450 (1968).

(36) M. C. Bowman and M. Beroza, *Anal. Chem.*, **40**, 1448 (1968).

(37) M. C. Bowman and M. Beroza, *J. Chromatogr. Sci.*, **7**, 484 (1969).

(38) P. A. Wilks, Jr., and R. A. Brown, *Anal. Chem.*, **36**, 1896 (1964).

(39) J. Merritt, F. Comendant, S. T. Abrams, and V. N. Smith, *ibid.*, **35**, 1461 (1963).

gions with both fast-scan detectors and those that follow one or two wavelengths. Usually these scans are made "on the fly" with the compound in the vapor state. However, a flowing liquid interface has also been used to pick up compounds emerging from a gas chromatograph and transfer them to a spectrofluorometer that registers its response on a recorder.⁴⁰ Each of these combinations can provide a specific type of data (*e.g.*, the presence of a given functional group) usually with very small amounts of sample.

Perhaps the most elegant of the detectors is a fast-scan mass spectrometer.^{41,42} The gas chromatograph separates substances in pure form for the instrument and also acts as an inlet system (introduction device), especially for small samples. The mass spectrum is sufficiently detailed in many instances to allow considerable and sometimes entire elucidation of structure on a fraction of a microgram. By scanning the front, center, and rear of a peak, the chemist can also appraise the purity of the compound generating the peak. With a high-resolution double-focusing instrument,⁴³ the empirical formula corresponding to each line in a mass spectrum can be determined (to give an element map). This information is especially valuable for the parent peak—*i.e.*, it gives the complete elemental composition of a compound—and such information can often be obtained on 1 μg !

Yet a mass spectrometer does not replace the need for the other detectors cited because it normally requires pure material for analysis. The highly specific response of some of these detectors allows the estimation of compounds with responsive elements of groupings even though much extraneous material is present. The isolation of these compounds is thereby facilitated.

The most sensitive of all detectors is a biological one. The human nose has been used to detect the active ingredients of odor and flavor essences at levels that do not register on a gas chromatograph. Bayer and Anders⁴⁴ caused male moths to exhibit a characteristic wing movement and whirling dance when exposed to as little as 10^{-17} g of female sex attractant/ml of carrier gas.

Summary and Outlook

A variety of gas chromatographic techniques and procedures have been paraded before the reader. At the microgram level, the carbon skeleton can be determined, compounds can be checked for double bonds and

their saturated analogs prepared quickly and easily, double bonds can be located by ozonolysis, subtraction loops can frequently tell us something about the functional groups in a molecule, and in many instances specialized detectors can be used to determine the elements, functional groups, or even the complete structure of a molecule. These procedures can be used to supplement the data derived from spectral examination and possibly to contribute to a scheme for determining chemical structure at the microgram level.

As the spectral techniques (*e.g.*, ir, uv, nmr) have gained favor, less attention has been paid to such classical procedures for structure elucidation as degradations and chemical reactions. These procedures can often be modified to utilize some of the new sophisticated instrumentation that has become available, and valuable structural data can be secured with very little sample. The potential for developing analytical methodology of this kind as an adjunct of gas chromatography is great. For example, the gas chromatograph provides a well-controlled flexible system in which chemical reactions may be conducted on substances that can be volatilized or changed to volatile products, and the products of the reaction can be analyzed easily, both qualitatively (by retention time) and quantitatively (by magnitude of response). The constant flow rate of the carrier gas affords a precise time interval for contact of a substance with a reaction zone and for the removal of the products from the reaction zone. Control of the reactor length and temperature, the concentration of chemical in the reactor, and the flow rate of the carrier gas make for considerable flexibility in the choice of reaction conditions. Thus, classical methodology may be speeded and simplified through the use of a high-temperature tubular reactor. Losses are minimized and problems related to the transfer of small amounts of substance are eliminated because the reactions are carried out in a closed system. These advantages are augmented by the availability of detectors, instrumentation, and electronic gear that are continually being improved.

There is a healthy trend toward deriving more information on chemical structure from less material, and this trend may be expected to continue with vigor. The ability to identify successfully and efficiently lesser quantities of compound is leading not only to solutions of problems previously considered insoluble, but it also is opening new areas of scientific endeavor as they spring into focus.

I wish to thank my coworkers R. Sarmiento, B.A. Bierl, and M. C. Bowman for their support in the conduct of this research.

(40) M. C. Bowman and M. Beroza, *Anal. Chem.*, **40**, 535 (1968).

(41) R. S. Gohlke, *ibid.*, **31**, 535 (1959).

(42) R. Ryhage, *ibid.*, **36**, 759 (1964).

(43) J. T. Watson and K. Biemann, *ibid.*, **37**, 844 (1965).

(44) E. Bayer and F. Anders, *Naturwissenschaften*, **46**, 380 (1959).